

# DATA SHEET

## Gear Assembly Set G95, 1:95

Item no. **96752**

**Motor for micro-models, enclosed. Brass with steel axle, developed specifically for 1:87 lorries.**

Originally developed as a motor for 1:87 lorries, this small gear unit is also excellently suited for light motors on larger vehicles. It can even be used to implement winches and special functions. The G95 is an enclosed gear assembly set with a gear reduction of 1:95. Ideal for street and off-road lorries.

The gear assembly set is screwed together, so it can always be disassembled and is service-friendly. The G95 further has M1 mounting holes and can therefore be screwed to the vehicle frame. Because of its compact size the G95 can be built into the vehicle frame to even build tractor units.

Gear assembly set G95

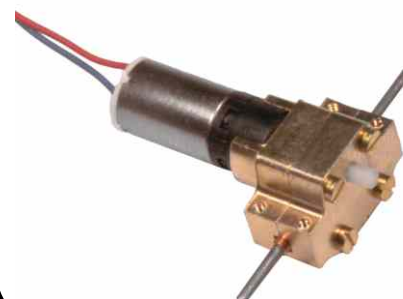

### Mechanical data:

Length	20 mm
Width (axle beam)	12 mm
Width (between frame sides)	8.5 mm
Height	9 mm
Height (axle to bottom edge)	4 mm
Weight	4.5
Ratio	1:95
<b>Electrical data:</b>	
Voltage:	3.7 V

### Dimension:

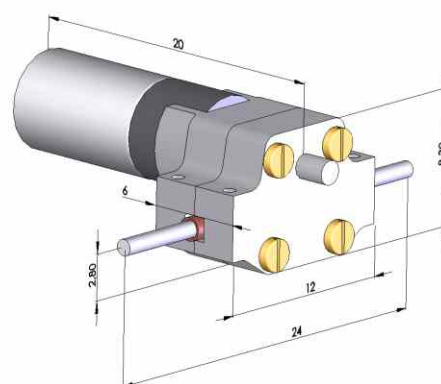

### Application examples:

